

KUBE C172 Standard Dual Pyroelectric Sensor

for all PIR motion detectors, including
lighting and intrusion alarm detectors.

Features:

- Two physically separated sensing elements (series opposed dual)
- Radiation falling on both active areas simultaneously is cancelled
- TO-5 style sealed metal housing
- Includes JFET and optical filter window
- Broad optical bandwidth (5 to 25 μm) for maximum signal, but still good white light immunity
- For use with all KUBE lenses and TR230 Cone Optics
- Excellent long term stability. Proven reliability under high humidity conditions
- Low noise / low false alarm rate
- RoHS conform

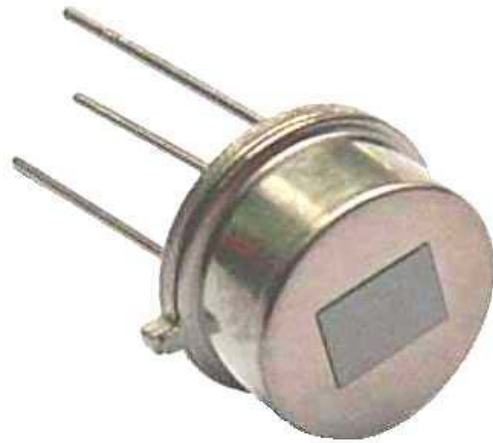

Characteristics	Value	Unit	Test Conditions
Element size (typ)	1.0 x 2.0	mm	nominal, each
Element spacing (typ)	1.0	mm	nominal
Optical wavelength	5 ... 25	μm	7 ... 14 μm $\geq 70\%$
Responsivity (typ)	2700	V/W	7 ... 14 μm @ 1Hz
Common mode rejection ratio (typ)	15:1 min 1:7		7 ... 14 μm @ 1Hz
Noise (typ)	5.1	$\mu\text{V} / \sqrt{\text{Hz}}$	1.0 Hz rms, 1Hz
Operating voltage	2.2 ... 10	V_{dc}	V_{D} to Ground
Offset voltage	0.3 ... 1.2	V_{dc}	$R_{\text{S}} = 100 \text{ k}\Omega$
Operating drain current	0.2 ... 10	μA	(recommended range)
Thermal breakpoint f_{T} (typ)	0.2	Hz	
Electrical breakpoint f_{e} (typ)	0.05	Hz	
Field of view (horizontal)	138	degrees	from center between sensing elements
Field of view (vertical)	~125	degrees	
Window Filter size	4.0 x 3.0	mm	
Operating temperature	-20 ... +50	$^{\circ}\text{C}$	-30...+70 $^{\circ}$ with precautions
Storage temperature	-40 ... +80	$^{\circ}\text{C}$	change < 50 $^{\circ}\text{C}$ / minute

Recommendations:

- A source resistor is needed to set the drain current and consequently the operating parameters of the internal JFET. A 47 k Ω or greater value resistor is recommended. For low power applications (0.2 μA), a source resistor of 3.3 M Ω can be used.
- The supply voltage must be stabilized (free of voltage steps and low frequency variations). This is best accomplished with a regulator or voltage reference chip, and RC filtering.
- Careful circuit board layout, short connections and shielding may be required for adequate RF immunity.
- For best quality, use well controlled hand soldering for pyroelectric sensors. Wave soldering is not recommended. Avoid mechanical stresses on the leads.
- If needed, clean window with alcohol to remove flux and fingerprints.
- Do not apply varnish, lacquer, silicone or other transparent coatings on window, as these materials will not transmit IR.

Internal circuit and pinout:

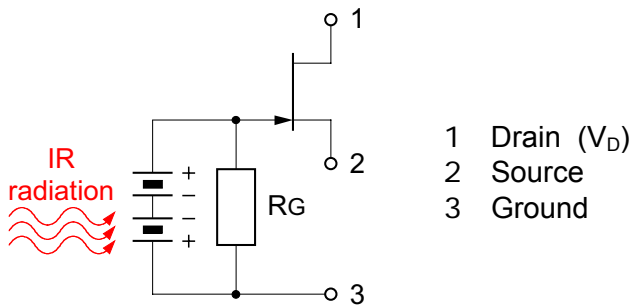

Drawing and Field of View:

